

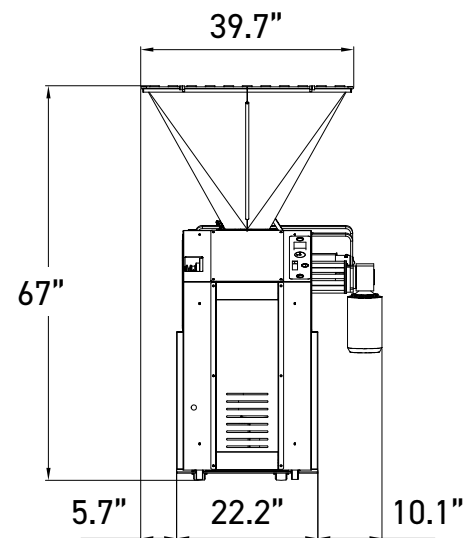

GDS

- ✓ Open hopper volumetric divider
- ✓ Stainless steel exterior
- ✓ Consistently accurate scaling
- ✓ High volume
- ✓ Built-in flour dispenser
- ✓ Pre-rounding of dough pieces
- ✓ 5 years parts / 1 year labor warranty

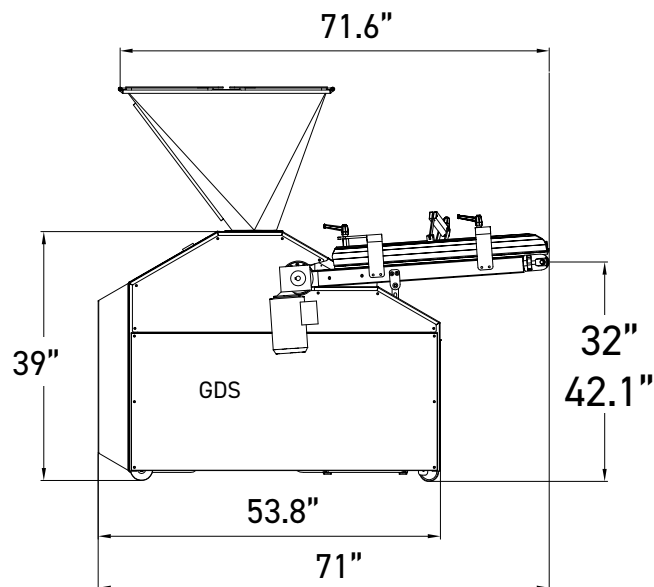



Outfeed belt scraper
The belt is kept clean throughout use.



Oil recycling system
Reduces oil consumption.
Fitted with a filter and a low level alert.



Adjustable pre-rounding
Pre-round dough balls on the outfeed belt.



Option
Built-in flour dispenser
Prevents the dough pieces from sticking to the belt.



Option
Moulding plate



Option
Dough piece lubrication

FEATURES

| GDS | |
|--|--------------------|
| Adjustable speed in pieces per hour | 960 - 2000 |
| Teflon-coated hopper. capacity in ounces | 4230 oz |
| Capacity in pounds | 260 lbs |
| Programmable counter. countdown counter | • |
| Stainless steel drum | • |
| Triple-seal Rilsan piston | • |
| Stainless steel exterior | • |
| Outfeed belt width in in | 19.7" |
| Outfeed belt scraper | • |
| Adjustable pre-rounding tile | • |
| Oil recycling system | • |
| Motor power in kW | 2.2 |
| Type of motor | 3ph/208V/60Hz/4.7A |
| Net weight in lbs | 1270 |

CHOICES

| | |
|---------------------------|-------|
| Outfeed belt length in in | 41.7" |
|---------------------------|-------|

OPTIONS

| | |
|---|---|
| Flour dispenser | • |
| Dough piece lubrication | • |
| 440lb capacity Teflon-coated stainless steel hopper | • |
| Extracting dough pieces device | • (as standard on 3.14"piston and 3.94" piston) |
| Dough piece rolling belt | • |

| | 3.14" PISTON | 3.94" PISTON | 4.33"PISTON | 4.72" PISTON | 5.12" PISTON |
|--|--------------|---------------|--------------|---------------|---------------|
| Max/min weight of dough pieces in ounces | 1 / 13 oz | 1.7 / 24.7 oz | 2.47 / 30 oz | 3.2 / 35.3 oz | 4.6 / 45.8 oz |