

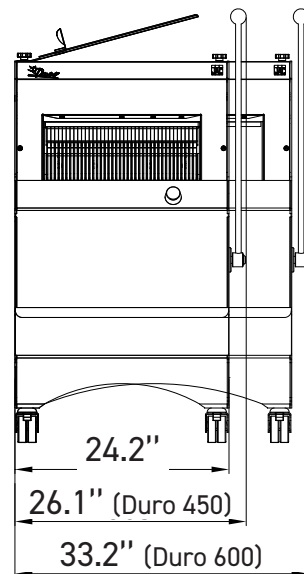

Duro

- ✓ Robust construction
- ✓ Progressive traction lever
- ✓ Available as single or dual slice models
- ✓ 5 years parts / 1 year labor warranty

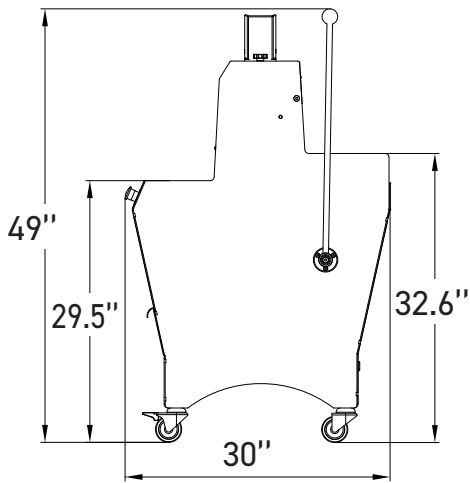



Progressive traction lever
Provides better control.

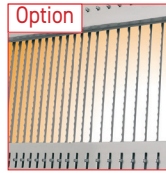

Option
Double slice thickness
Allows two different slice thicknesses on the same machine.



Removable crumb collector
Accessible from the front, collects up to 4 gallons of crumbs.



Option
1.6" height adjustment
Increases working comfort for tall operators.



Bagging spade
For easy bagging of sliced loaves.

FEATURES

	DURO 450	DURO 600
Max. loaf dimensions in in (L x W x H)	17.3" x 12.6" x 6.3"	23.6" x 12.6" x 6.3"
Motor power in kW	0.49	0.49
Type of motor	1ph/120V/60Hz/7.3A	1ph/120V/60Hz/7.3A
Plug Configuration	NEMA 5-15P*	NEMA 5-15P*
Net weight in lbs	331	386
Rear safety cover		.

OPTIONS

1.6" height adjustment	.	.
Double slice thickness		.

SLICE THICKNESS	
INCH TO MM	
3/8"	10
7/16"	11
1/2"	13
5/8"	16
3/4"	19
7/8"	22
1"	25
1 1/4"	31

